

# Model 975XL3

# LEAD-FREE\*

# WILKINS®

Reduced Pressure Principle Assembly (1/2", 3/4", 1", 1 1/4", 1 1/2" & 2")

\*This product contains a weighted average lead content less than 0.25% for wetted surfaces.

\*Meets the requirements of NSF/ANSI/CAN 61 and 372.

(Patent zurn.com/patents)

## □ Installation □ Testing □ Maintenance Instructions

### INSTALLATION INSTRUCTIONS

**CAUTION:** Installation of Backflow Preventers must be performed by qualified, licensed personnel. The installer should be sure the proper device has been selected for the particular installation. Faulty installation could result in an improperly functioning device.

WILKINS Model 975XL3 Reduced Pressure Principle Backflow Preventers are for use on potable water lines where a health hazard could exist if a backflow situation were to occur.

Proper performance is dependent upon following these installation instructions and prevailing governmental and industry standards and codes. Failure to do so, according to WILKINS Limited Warranty "...releases WILKINS of any liability that it might otherwise have with respect to that device." Such failure could also result in an improperly functioning device.

Damage to the device could result wherever water hammer and/or water thermal expansion could create excessive line pressure. Where this could occur, shock arresters and/or pressure relief valves should be installed downstream of the device.

1. Before installing a Model 975XL3 Backflow Preventer, flush the line thoroughly to remove all debris, chips and other foreign matter. If required, a lead-free strainer should be placed upstream of the Backflow Preventer.  
**CAUTION: Do not use a strainer in seldom used emergency waterlines such as fire lines.**
2. The Model 975XL3 must be installed in a horizontal position to provide proper operation of the relief valve.
3. Provide adequate space around the installed unit so that the test cocks will be accessible for testing and servicing.  
**CAUTION: Do not pipe the relief valve solidly to a floor drain, sewer or sump.**
4. Install valve at least 12 inches above surrounding flood level.

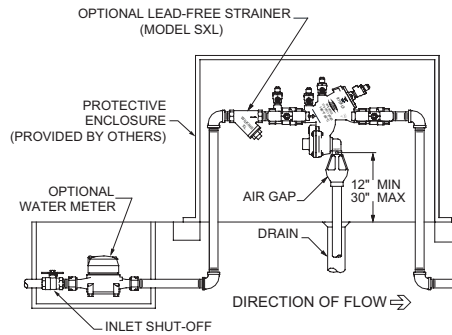

5. Always consult local codes for installation methods, approvals and guidance

If installation of a Model 975XL3 is in a building, provide a suitable drain arrangement to drain off spillage from the relief valve. An air gap at least two times the pipe diameter must be provided between the relief valve and the drain piping to prevent a cross-connection.

### OUTDOOR INSTALLATION

Model 975XL3 Backflow Preventer may be installed outdoors only if the device is protected against freezing conditions. Exposure to freezing conditions will result in improper function or damage to the device. The installation location must be kept above 32°F. All the basic installation instructions apply.

If installation is in a pit or vault, the Backflow Preventer must never be submerged in water because this could cause a cross-connection. Make sure that the pit or vault always remains dry by providing ample drainage.

### INDOOR INSTALLATION

Indoor installation is preferred in areas that are subject to freezing conditions. All the basic installation instructions apply to such installations.

### PARALLEL INSTALLATION

Where uninterrupted service from a single meter connection must be maintained, two or more Backflow Preventers may be connected in parallel. All the basic installation instructions apply to parallel installation. Be sure to allow adequate room between the units for testing and repair.

### PLACING THE DEVICE IN SERVICE

After the installation of a Model 975XL3 has been completed, place the unit in service as follows:

1. Start with both shut-off valves closed. Slowly open the inlet shut-off valve until the backflow preventer is completely pressurized. A brief discharge from the relief valve may occur while the device is pressurizing. The discharge should cease by the time the shut-off valve is fully open. Device should function properly. If the discharge does not stop, refer to "Maintenance Instructions" for repair procedures.
2. After the device has been pressurized, vent all trapped air from both check valve by slightly opening each of the four test cocks.
3. Slowly open the downstream shut-off valve. The Model 975XL3 Reduced Pressure Principle Backflow Preventer is now in service.
4. If "spitting" or intermittent discharges from the relief valve are noted, it could be a result of pressure fluctuation and/or a water hammer condition in the system. If such conditions exist, install water pressure reducing valves or water hammer shock arresters in compliance with industry standards as needed.
5. After the Model 975XL3 has been properly installed, test the device (see "Testing Procedures"). If the device fails the test, remove the first and second check valves and thoroughly flush the device. If the relief valve fails to operate properly, inspect the sensing passage for clogging (see "Maintenance Instructions"). Clean rubber seals and seats of all debris and place unit back in service.

⚠ **WARNING:** Cancer and Reproductive Harm - [www.P65Warnings.ca.gov](http://www.P65Warnings.ca.gov)  
⚠ **ADVERTENCIA:** Cáncer y daño reproductivo - [www.P65Warnings.ca.gov](http://www.P65Warnings.ca.gov)  
⚠ **AVERTISSEMENT:** Cancer et néfastes sur la reproduction - [www.P65Warnings.ca.gov](http://www.P65Warnings.ca.gov)

# Testing Procedures

## MODEL 975XL3 REDUCED PRESSURE PRINCIPLE ASSEMBLY

Equipment Required: Differential pressure gauge test kit.

### TEST NO. 1 - RELIEF VALVE OPENING POINT

#### REQUIREMENT:

The differential pressure relief valve must operate to maintain the zone between the two check valves at least 2 psi less than the supply pressure.

#### PROCEDURE:

1. Flush water through test cocks #1, #2 (open #2 slowly), #3 and #4 by opening and closing each test cock one at a time, to eliminate foreign material.
2. Install appropriate fittings to test cocks. Attach hose from the high side of the differential pressure gauge to the #2 test cock then attach hose from the low side of the gauge to the #3 test cock. Open test cock #3 slowly and then bleed all air from the hose and gauge by opening the low side bleed needle valve.
3. Maintain the low side bleed needle valve in the open position while test cock #2 is opened slowly. Open the high side bleed needle valve to bleed all air from the hose and gauge. Close the high side bleed needle valve, then close the low side bleed needle valve after the gauge reading has reached the upper end of the scale.
4. Close the #2 shut-off valve. If the gauge reading drops to the low end of the gauge scale and the differential pressure relief valve discharges continuously, then the #1 check valve is leaking. If this occurs, Tests #1, #2 and #3 cannot be completed (See USC Maintenance Guide). However, should the gauge reading remain above the differential pressure relief valve opening point, then observe the gauge reading. This is the apparent pressure drop across the #1 check valve.
5. Open the high side control needle valve approximately one turn, and then open the low side control needle valve no more than 1/4 turn to by-pass water from the #2 test cock to the #3 test cock. Observe the differential pressure reading as it slowly drops to the relief valve opening point. Record this opening point value when the first discharge of water is detected. Close the low side needle valve.

### TEST NO. 2 - TIGHTNESS OF #2 CHECK VALVE

#### REQUIREMENT:

The #2 check valve shall be tight against backpressure.

#### PROCEDURE:

1. Maintain the #2 shut-off valve in the closed position (from Test #1). Vent all air through the vent hose by opening the vent needle valve. Close the vent needle valve only (The high side control needle valve is to remain open).
2. Attach the vent hose from the gauge to the #4 test cock, then open the #4 test cock. Bleed water from the zone by opening the low side bleed needle valve on the gauge in order to re-establish the normal reduced pressure within the zone. Once the gauge reading reaches a value above the #1 check valve pressure drop, close the low side bleed needle valve.

3. Open the vent needle valve. If the indicated differential pressure reading remains steady then the #2 check valve is reported as "closed tight." Go to Test #3. If the differential pressure reading falls to the relief valve opening point, bleed water through the low side bleed needle valve until the gauge reading reaches a value above the #1 check valve pressure drop. If the gauge reading settles above the relief valve opening point, record the #2 check valve as "closed tight," and proceed to Test #3. If the differential pressure reading falls to the relief valve opening point again, then the #2 check valve is noted as "leaking," and Test #3 cannot be completed. If the differential pressure reading drops, but stabilizes above the relief valve opening point, the #2 check valve can still be reported as "closed tight."

**Note:** Due to disc compression, you may need to bleed off water through low side bleed needle valve several times before the gauge reading will settle above relief valve opening point.

### TEST NO.3 - TIGHTNESS OF #1 CHECK VALVE

#### REQUIREMENT:

The static pressure drop across #1 check valve shall be at least 3.0 psi greater than the relief valve opening point (Test #1).

#### PROCEDURE:

1. With the vent hose connected to test cock #4 as in step 3 of Test #2, bleed water from the zone through the low side bleed needle valve on the gauge until the reading exceeds the #1 check valve pressure drop. Close the low side bleed needle valve. After the gauge reading settles, the steady state differential pressure reading indicated (reading is not falling on the gauge) is the actual static (i.e., no flow) pressure drop across check valve #1 and is to be recorded as such.
2. Close all test cocks, slowly open shutoff valve #2 and remove equipment.

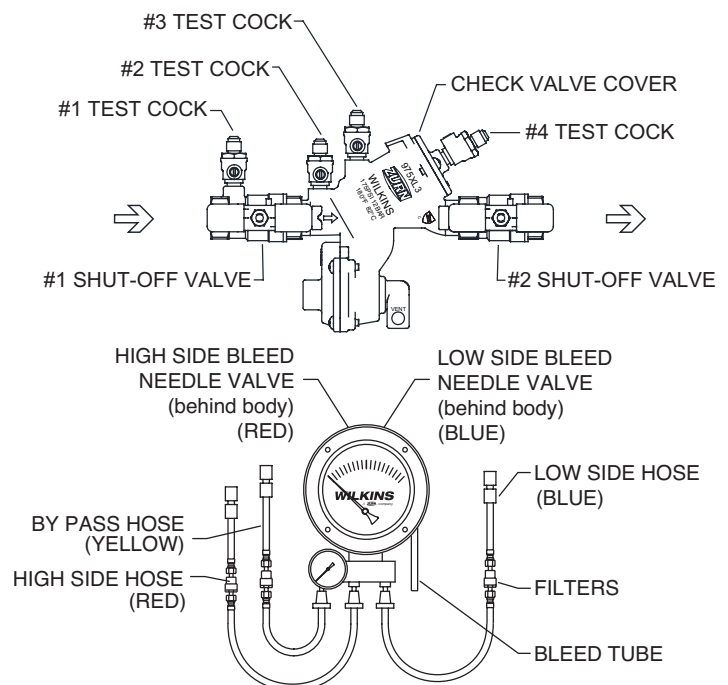

# Maintenance Instructions

All Model 975XL3 Reduced Pressure Principle Backflow Preventers must be inspected and maintained by licensed personnel at least once a year or more frequently as specified by local codes. Replacement of worn or damaged parts must only be made with genuine "WILKINS" parts. The WILKINS Certificate of Limited Warranty provides that failure to do so "...releases WILKINS of any liability that it might otherwise have with respect to that device." Such failure could also result in an improperly functioning device.

The Model 975XL3 Reduced Pressure Principle Assemblies should be thoroughly flushed after backflow conditions occur to prevent any type of corrosive deterioration to its components. Failure to do so could result in malfunction of the device.

## GENERAL MAINTENANCE

1. Clean all parts thoroughly with water after disassembly.
2. Carefully inspect rubber seal rings, diaphragms and o-rings for damage.
3. Test unit after reassembly for proper operation (see "Testing Procedures").

## SERVICING CHECK VALVES

1. Close inlet and outlet shut-off valves.
2. Open No. 2, No. 3 and No. 4 test cocks to release pressure from valve.
3. Unscrew check valve cover screws using appropriately sized wrench or screwdriver.
4. Remove check valve cover and check cartridge assembly.
5. Inspect rubber o-rings for cuts or embedded debris.
6. Press and rotate #2 spring retainer to remove #2 poppet. Press and rotate #2 seat to remove #1 poppet. **CAUTION: Checks are spring loaded. Take extra care with 2" valves, as these springs are longer and stiffer than other sizes.**

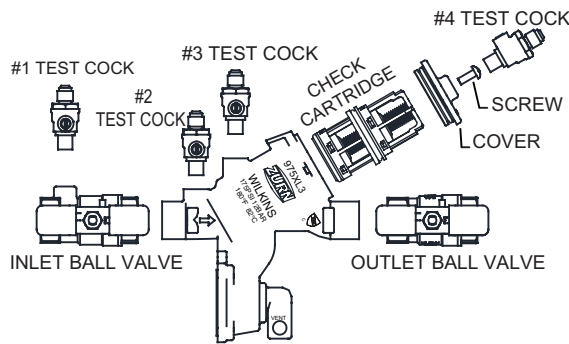

7. Inspect rubber seal ring for cuts or embedded debris.
8. To remove seal ring, remove screw and washer.
9. If the reverse side of the seal ring is unused, it is possible to invert the seal ring. This would be considered a temporary solution to fixing a fouled check and should be replaced with a new seal ring as soon as possible.
10. Inspect both seats for wear on the seating surface. If damaged, replace seat.
11. Inspect valve cavity and remove any debris.
12. Reverse the above procedure to reinstall check valve assembly and check cover, making sure the 3 test cocks remain open. Care should be taken to ensure the heavier of the two springs is installed in the #1 check.

## SERVICING RELIEF VALVE

1. Remove relief valve cover bolts and cover. Gently pull on diaphragm to remove the cartridge assembly.
2. Inspect seal ring for cuts and embedded debris. If reverse side of seal ring is unused, it is possible to invert the seal ring. This would be considered a temporary solution and the seal ring should be replaced as soon as possible.
3. Disassemble cartridge by unscrewing relief valve retaining screw.
4. Inspect diaphragm, o-rings and/or cup seal for damage. Replace required parts and apply a light coat of grease to plunger o-ring or cup seal.
5. Carefully reassemble cartridge assembly. Ensure proper cup seal orientation as shown below, when applicable.
6. Inspect relief valve seat for wear on seating surface. If damaged, replace seat and seat o-ring.
7. Insert cartridge assembly into relief valve body.
8. Replace relief valve cover and cover bolts.
9. Place device in service and test per "Testing Procedures".

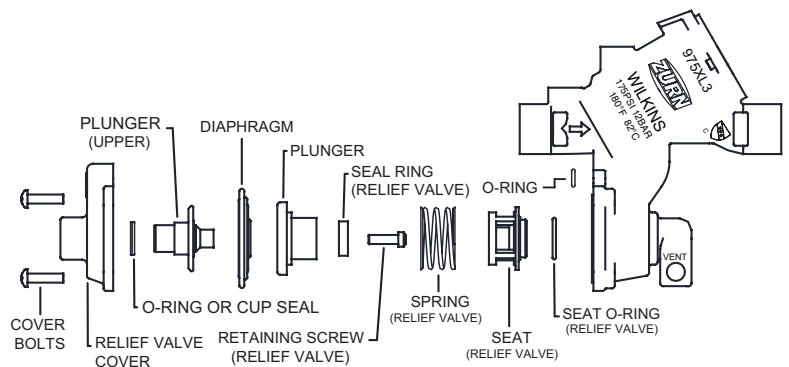
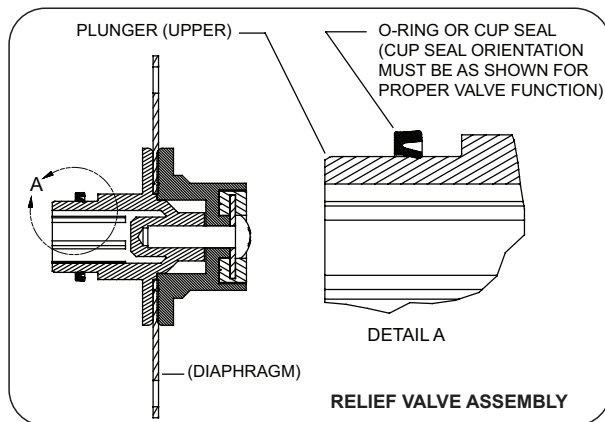
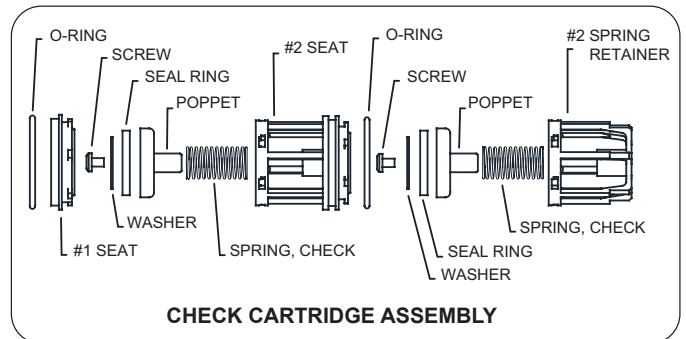

## Relief Valve Reassembly

1. Install the o-ring or cup seal on the relief valve plunger as shown.
2. **Ensure cup section of the cup seal faces the plunger, when applicable. See detail view above.**
3. Insert relief valve assembly into relief valve body.
4. Do not force relief valve cover onto relief valve assembly if cover binds on o-ring or cup seal.

**Warning:** Damage to o-ring or cup seal during installation can potentially negatively affect operation and proper sealing.

# Wiring Diagram for 975XL3BFSS

**NOTE:** Model 975XL3BFSS features Wilkins model 49BRXLSST butterfly valves with supervisory switch. The gearbox ships from the factory with a cable gland to protect the internals from dust and moisture during shipping, storage, and installation. For outdoor installations the electrical contractor shall remove the cable gland prior to installing the appropriate conduit and junction box for making the supervisory switch connections outlined below. Steps shall be taken to ensure that the connection to the gearbox forms a watertight seal. Failure to do so may result in water intrusion that may cause the switch to malfunction. Contact the factory for a replacement switch if needed.

Green Lead provided is ground for switch housing  
 Switch Rating: 10AMP/ 115 VAC  
 .5AMP/28 VDC  
 Cap unused leads with wire nuts and tuck inside junction box (not provided)  
 NOTE: Supervisory tamper switches are for **indoor and outdoor use.**

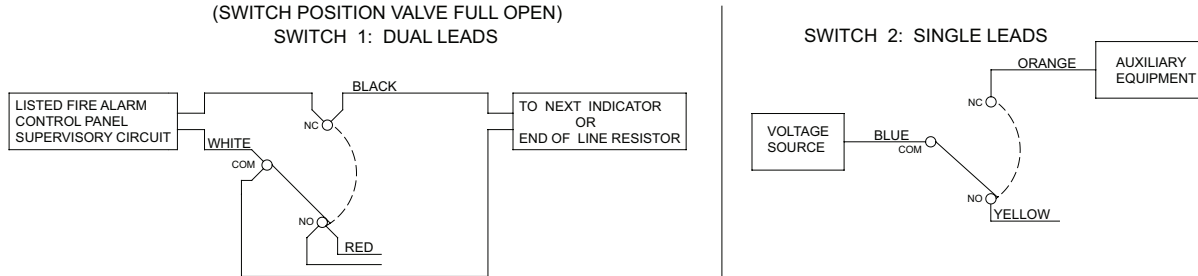

## Troubleshooting

When the relief valve discharges intermittently it can be almost always assumed that the device is functioning correctly and that the discharge is caused by systems such as inlet pressure fluctuations or water hammer due to quick closing valves.

PROBLEM	POSSIBLE CAUSES	CORRECTIVE ACTION
1. <b>SUDDEN OR RAPID SPITTING</b>	1. Drop in inlet pressure. 2. Sudden increase in downstream pressure due to water hammer from quick closing shut-off valve installed downstream.	A. Install an in-line spring loaded check valve upstream of backflow. B. Install pressure reducing valve upstream of backflow unit. C. Install in-line spring loaded check valve downstream of backflow as close to source as possible, but not closer than 4 feet.
2. <b>LIGHT INTERMITTENT DRIP</b>	1. Slightly fouled #1 check.	A. Clean #1 check and turn check valve seal ring over or replace.

Continuous discharge of the relief valve signifies a failure of some part of the device. To help determine the specific area of failure, close the #2 shut-off valve. If the discharge stops, the #2 check requires service. If the discharge continues, the #1 check requires service.

1. <b>CONTINUOUS DISCHARGE</b>	1. Fouled #1 check. 2. Fouled relief valve seat. 3. Fouled #2 check	A. Clean check valves and turn check valve seal rings over or replace. B. Clean relief valve seat and turn relief valve seal ring over or replace.
--------------------------------	---	---

The amount of discharge is proportional to degree of fouling. Most problems occur in the #1 check which is where debris enters the backflow preventer first.

## Performance Characteristics

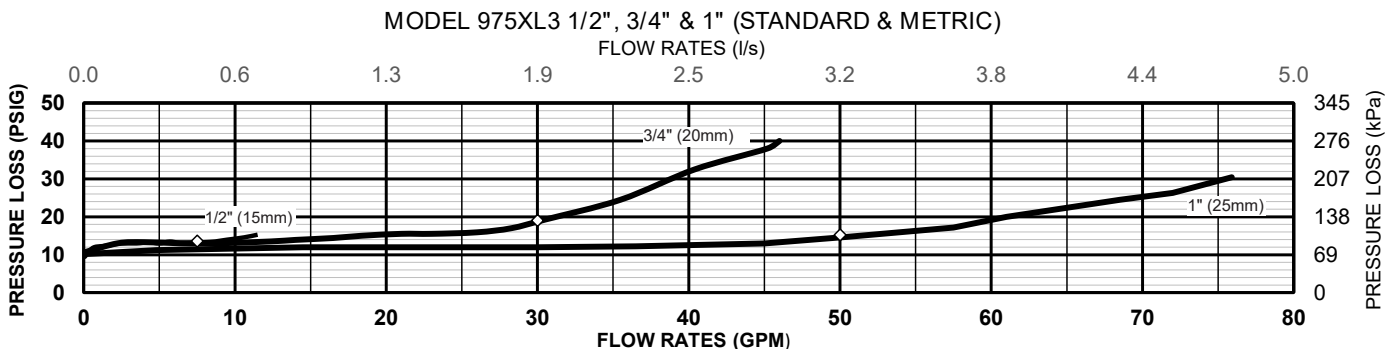

MODEL 975XL3 1 1/4", 1 1/2" & 2" (STANDARD & METRIC)

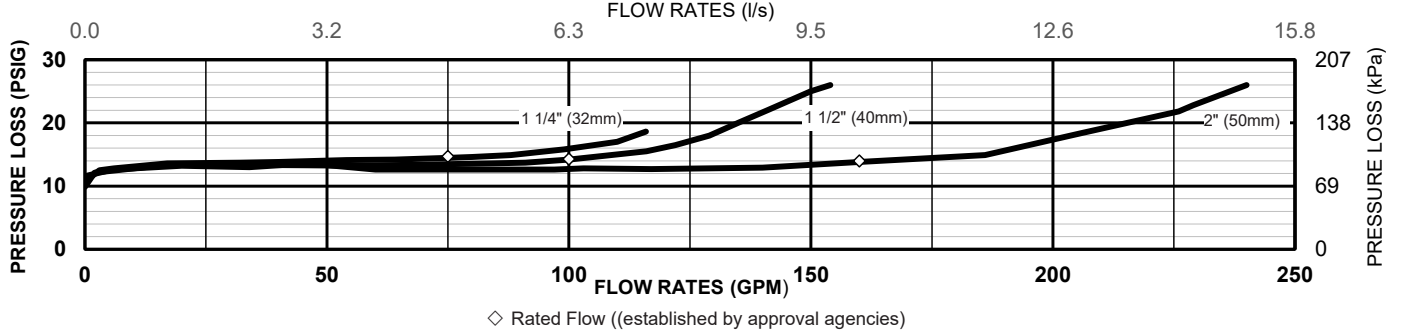

◇ Rated Flow ((established by approval agencies)

Capacity thru Schedule 40 Pipe (GPM)				
Pipe size	5 ft/sec	7.5 ft/sec	10 ft/sec	15 ft/sec
1/2	5	7	9	14
3/4"	8	12	17	25
1"	13	20	27	40
1 1/4"	23	35	47	70
1 1/2"	32	48	63	95
2"	52	78	105	167

<b>SPECIFICATIONS</b>	
Minimum working water pressure	25 PSI
Maximum working water pressure	175 PSI
Minimum working water temperature	33°F
Maximum working water temperature	180°F
Hydrostatic test pressure	350 PSI
Threaded end connections	ANSI B1.20.1

Proper performance is dependent upon licensed, qualified personnel performing regular, periodic testing according to WILKINS' specifications and prevailing governmental & industry standards and codes and upon following these installation instructions. Failure to do so releases WILKINS of any liability that it might otherwise have with respect to that device. Such failure could also result in an improperly functioning device.