



AquaSense®

ZER-SM Series

Automatic Battery-Powered Flush Valve

Installation, Operation, Maintenance and Parts Manual



**ZER6000-SM
Series**



**ZER6200-SM
Series**



**ZER6003-SM
Series**



**ZER6203-SM
Series**

LIMITED WARRANTY

All goods sold hereunder are warranted to be free from defects in material and factory workmanship for a period of three years from the date of purchase. Decorative finishes warranted for one year. We will replace at no costs goods that prove defective provided we are notified in writing of such defect and the goods are returned to us prepaid at Sanford, NC, with evidence that they have been properly maintained and used in accordance with instructions. We shall not be responsible for any labor charges or any loss, injury or damages whatsoever, including incidental or consequential damages. The sole and exclusive remedy shall be limited to the replacement of the defective goods. Before installation and use, the purchaser shall determine the suitability of the product for his intended use and the purchaser assumes all risk and liability whatever in connection therewith. Where permitted by law, the implied warranty of merchantability is expressly excluded. If the products sold hereunder are "consumer products," the implied warranty of merchantability is limited to a period of three years and shall be limited solely to the replacement of the defective goods. All weights stated in our catalogs and lists are approximate and are not guaranteed.

- ⚠ WARNING:** Cancer and Reproductive Harm - www.P65Warnings.ca.gov
- ⚠ ADVERTENCIA:** Cáncer y Daño Reproductivo - www.P65Warnings.ca.gov
- ⚠ AVERTISSEMENT:** Cancer et effet nocif sur la reproduction - www.P65Warnings.ca.gov

Rev. D | Date: 10/03/25 | C.N. No. 147216 | Prod./Dwg. No. FV828

Patent zurn.com/patents

US 1.855.ONE.ZURN CANADA 1.877.892.5216

ZURN.COM

by **ZURN ELKAY** Water Solutions

This Page Intentionally Left Blank

Specifications

Sensor Range: 12" to 60" (adjustable)

Power Type: Battery powered; 4x C size

Operating Water Pressure: 25 psi [172 kPa] Min (Running); 80 Psi [552 kPa] Max (Static)

Operating Temperature: 35°F to 104°F [2°C to 40°C]

Important Safety Information

- Do not convert or modify this Zurn product. All warranties will be voided.
- All plumbing is to be installed in accordance with applicable codes and regulations.
- Water supply lines must be sized to provide an adequate volume of water for each fixture.
- Flush all water lines prior to making connections.
- Do not use pipe sealant or plumbing grease on any fitting other than the control stop inlet.
- Sensor units should not be located across from each other or in close proximity to highly reflective surfaces.
- Control stop should never be opened to allow flow greater than fixture is capable of evacuating. In the event of valve failure, fixture must be able to handle a continuous flow.

Prior to Installation

- Before installing your flush valve, the items listed below should already be installed on-site:
 - Water closet or urinal fixture
 - Fixture carrier
 - Drain line
 - Water supply line

Package Contents

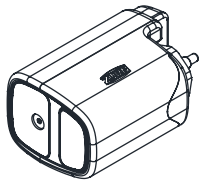

EZ Flush®



Control Stop
with Vandal Cap
(Optional with Aqua Flush)



Diaphragm
Valve Body

OR

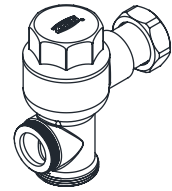

Piston
Valve Body

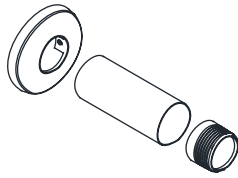

Sweat solder
Connection
with Cast Wall
Escutcheon

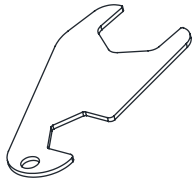

EZ Flush
Wrench

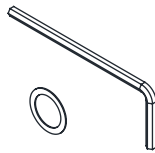

Hex Key
and Valve
Gasket

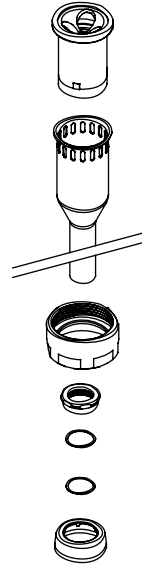

Vacuum Breaker
and Spud
Connection for
Urinal

OR

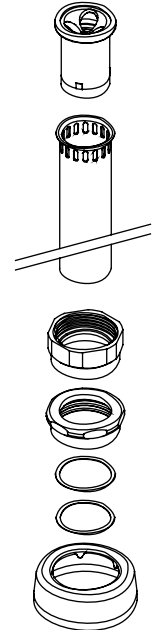

Vacuum Breaker
and Spud
Connection for
Water Closet

Required Tools

Optional Accessories

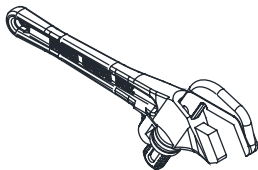

Smooth-Jawed
Adjustable Wrench



Magic Magnet
P6900-AT-MAG

Sweat Solder Adapter Installation

NOTE: Before installation, turn off water supplies to existing fixture and remove flushometer if replacing an existing device.

1. Measure distance from finished wall to the center line of the fixture spud. If necessary, cut water supply pipe 1-1/4" shorter than this measurement. Deburr by chamfering O.D. and I.D of end of water supply pipe.

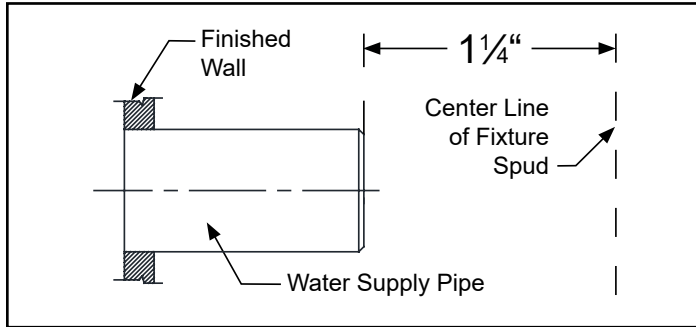

2. Slide threaded sweat solder adapter onto water supply pipe until shoulder stops on end of pipe. Then sweat-solder the adapter to water supply pipe.

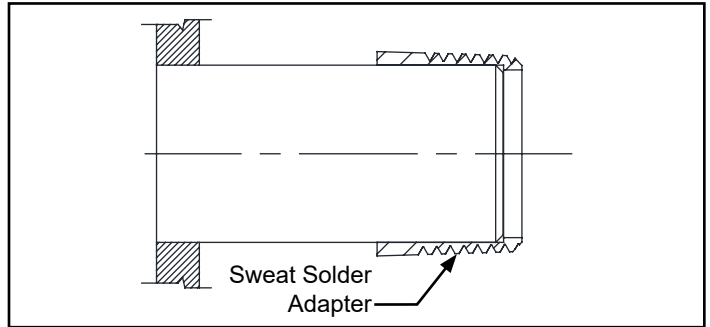

3. Measure distance from finished wall to first thread of sweat solder adapter. If necessary, cut chrome cover tube this length.

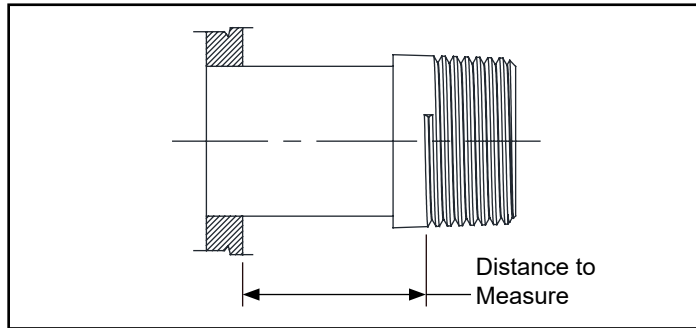

4. Slide wall escutcheon over chrome cover tube and slide both items over water supply pipe. Press wall escutcheon flush against finished wall and tighten set screw with hex wrench (supplied) to secure it in place.

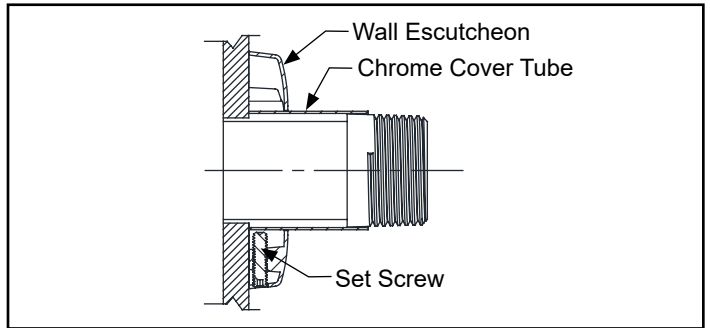

Control Stop Installation

1. Install control stop assembly by threading it onto water supply pipe and tightening with a smooth jawed wrench. Apply thread sealing compound or pipe tape to male NPT thread on sweat solder adapter only.

Prior to turning on main water supply line ensure all stop valves are closed off tight by using a flathead screwdriver and turning the stop valve adjustment screw clockwise.

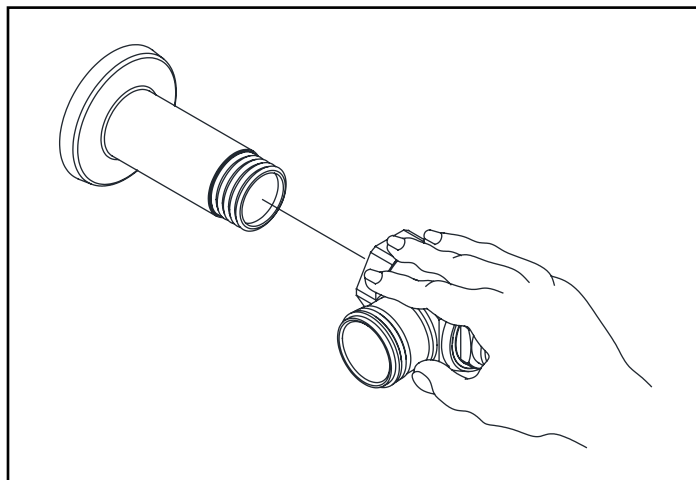

2. When all stop valves are properly connected to the water supply line and water pressure is available, open the control stop using a flat head screwdriver and turning the stop valve adjustment screw counterclockwise.

Allow the water supply line to flush any debris or sediment that may be present in the line. Close the control stop once the lines are completely flushed.

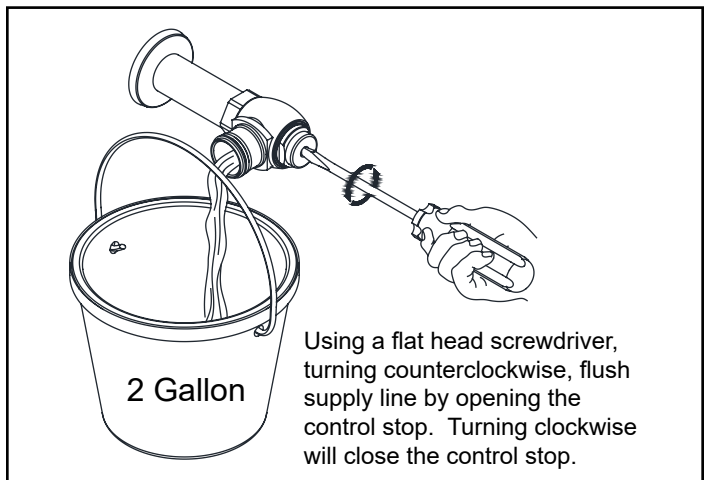

Flush Valve Installation

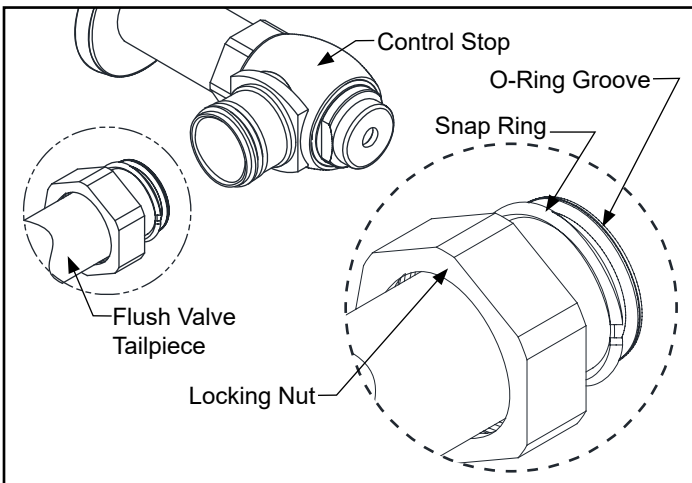

Prior to attaching flush valve tailpiece to control stop, inspect and verify that the O-ring seal is located within the O-ring groove at the tailpiece. Ensure that the locking nut and locking snap ring are also present on the tailpiece.

Lubricate O-ring with water if necessary and insert flush valve tailpiece into the control stop valve. Tighten locking nut using a smooth jawed wrench.

Vacuum Breaker & Flush Connection Installation

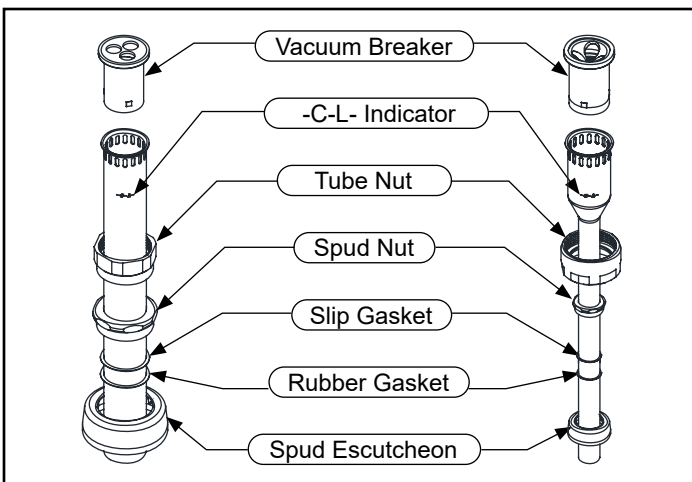

Determine the length of vacuum breaker tube required to join the flush valve and fixture spud, and cut if necessary.

Slide the tube nut, spud nut, slip gasket, rubber gasket and spud escutcheon over the vacuum breaker tube and insert tube into fixture spud. Hand tighten tube nut to valve body and hand tighten spud nut onto fixture spud. Adjust the valve assembly for plumb. Tighten fixture spud nut, vacuum breaker tube nut and locking nut with a wrench.

Adjust and plumb the valve assembly. Tighten all connections with smooth jawed wrench and turn on water supply at the control stop.

⚠ DO NOT cut vacuum breaker tube shorter than 6" below the -C-L- indicator mark, as vacuum breaker must be 6" above the fixture. Consult plumbing Codes & Regulations for specific details.

E-Z Flush Installation

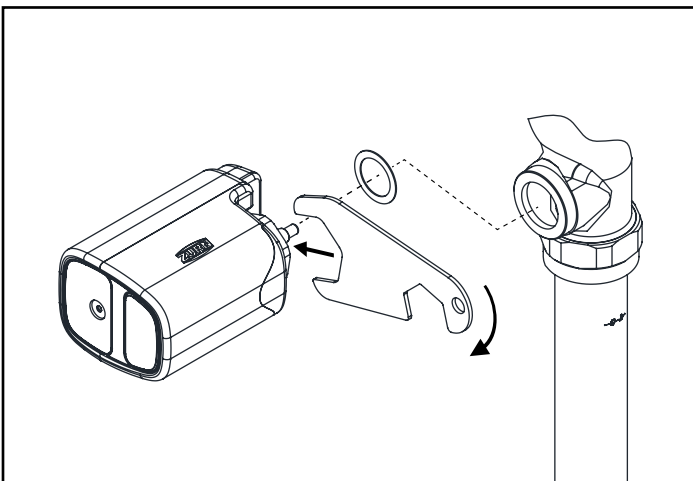

Place the supplied valve gasket onto the unit as shown. Use one hand to raise the unit to the handle port of the flush valve and use the other hand to rotate the unit's valve nut to begin engaging the threads of the valve body. Use the supplied wrench to tighten the EZ Flush unit securely to the valve body.

Flushing the System

When all flush valves are connected to the fixtures and water pressure is available, it is recommended that the supply piping be flushed to remove dirt, pipe chips, etc., from system.

Use the following procedure to flush out the supply piping:

1. Remove the main valve body cover.
2. Remove the working parts from the flush valve shown on the right
3. Replace the plastic cover and main body cover without reinstalling the working parts.
4. Open the stop valve by using the stop adjusting screw and flush out all debris from pipe and connections.
5. Shut stop, open cover, reinstall the working parts, replace both covers and tighten.

This procedure should also be repeated when the system is drained for seasonal use, as occurs in athletic fields, recreation parks, etc.

The ZER flush valves are preset for fixture volume as marked on the valve cartons. The valve does not require regulation for variation in water pressure within its operating range. To set the flush valve for proper operation, gradually adjust the stop valve until the rate of water flow into the fixture is not excessive, yet is sufficient to adequately evacuate the waste. The final setting for urinals should be such that the fixture will not overflow when the valve is actuated in succession. The stop cap screw cover should be replaced after final adjustments have been made.

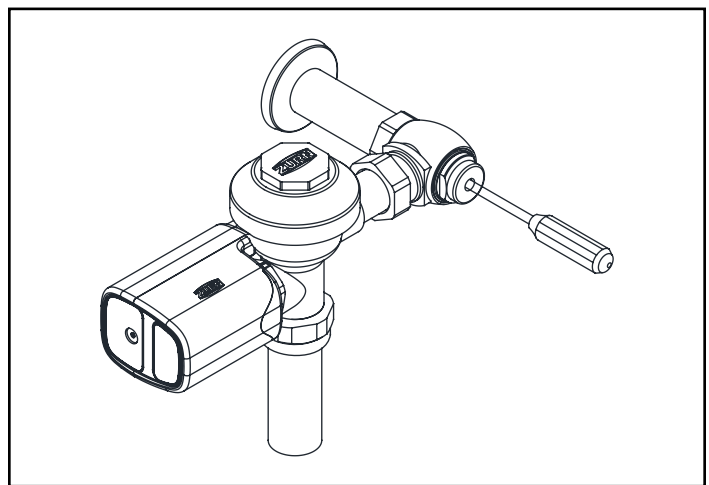
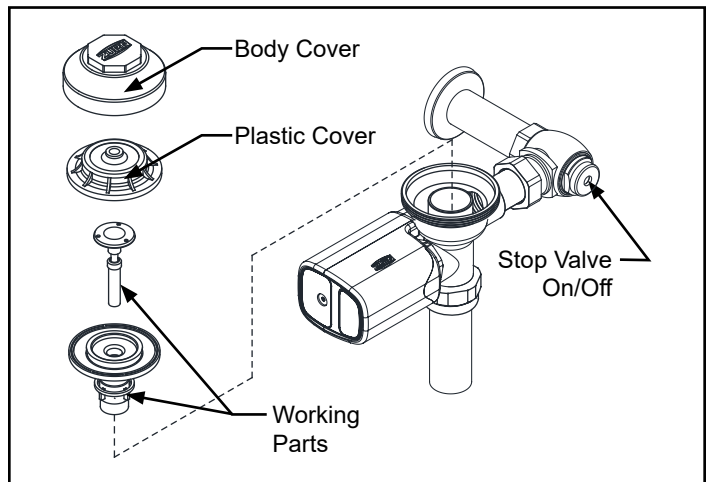

EZ Flush Activation

Using supplied hex key, remove battery compartment from the EZ Flush unit.

Load the supplied batteries into the battery tray. Note the battery orientation shown. Reinstall the battery tray into the EZ Flush unit using the hex key. The user LED will blink when the unit becomes powered.

Notes:

Your EZ Flush unit comes preset from the factory. If special circumstances require adjustment of the activation distance, see section of this manual "Adjusting Calibration Distance".

Each EZ Flush comes with a 24-hour flush mode that is disabled by default. To toggle this mode, see the section of this manual entitled "Toggling 24-Hour Line Flushing Mode".

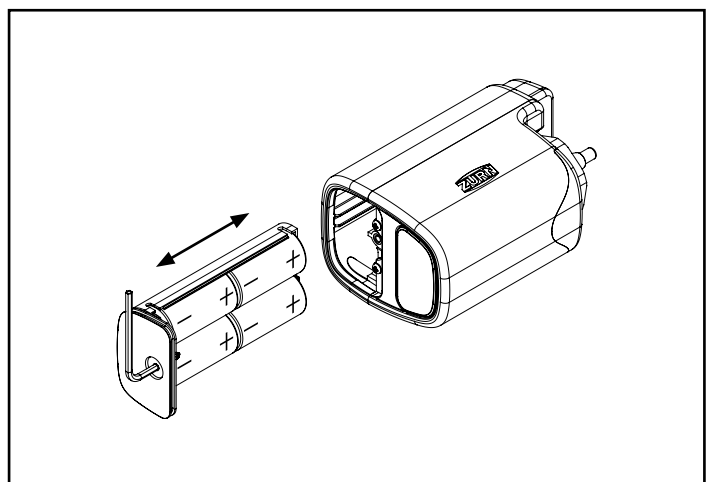

Adjusting Calibration Distance (Using the Magic Magnet)

Each EZ Flush comes calibrated from the factory to work optimally in most restroom environments. In low light or highly reflective environments however, it may be necessary to adjust the calibration distance of an EZ Flush unit. To do this, a Zurn Magic Magnet may be used. To re-calibrate an EZ Flush with a Magic Magnet, follow the procedure below: comes calibrated from the factory. To re-calibrate for a specific environment, follow these steps:

1. Stand at the desired calibration distance:
 - ~28" from the sensor in a water closet application.
 - ~22" from the sensor in a urinal application.
2. Raise the Magic Magnet to the top/bottom (depending on valve orientation - refer to image below) of the unit's lens until the user LED lights up.
3. Hold the Magic Magnet in that position until the user LED begins to blink. Remove the magnet and allow the user LED to blink 10 times while standing in the same position. A quick double-blink signals that the calibration is complete.
4. Test the new calibration distance by walking away from the unit for 5 seconds and returning to the position at which it was calibrated. Watch for the user LED to blink. If the user LED blinks, the calibration distance has been reset successfully.

Note: In water closet applications, it is a good idea to make sure that the new calibration distance does not allow the sensor to see the stall door. To check this, exit the stall and close the stall door for 10 seconds. Open the stall door. If the unit does not flush, the calibration distance is okay. If the unit flushes, you will need to recalibrate to a closer distance.

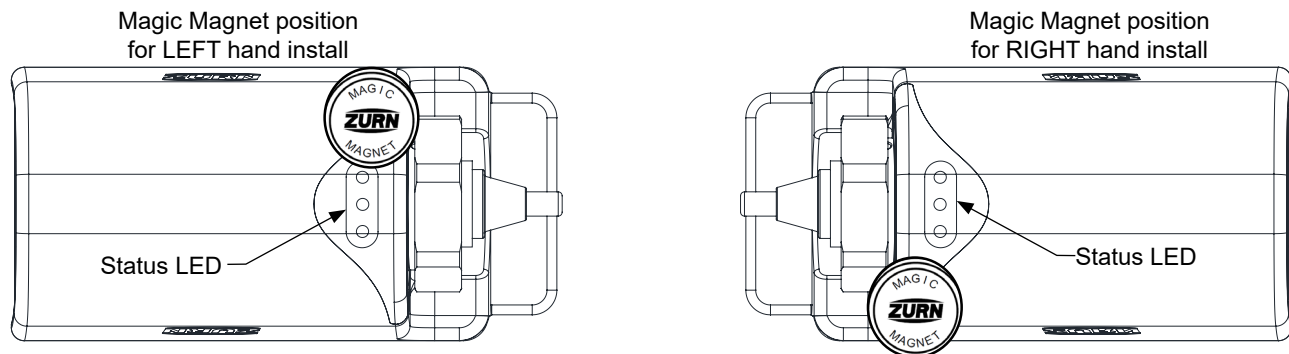

Toggling 24-Hour Line Flushing Mode (Using the Magic Magnet)

Each EZ Flush comes with a 24-hour line flushing feature that is disabled by default. This feature is intended for low-use applications where trap seal depletion is a concern. To toggle this feature, follow the procedure below:

1. Raise a Magic Magnet to the top/bottom (depending on valve orientation - refer to image above) until the user LED lights up.
2. Lower the magnet so that the user LED turns off.
3. Repeat this turn on / turn off procedure three more times.
4. After the fourth time, the user LED will display a series of rapid blinks. Three blinks signifies that the feature has been toggled on. Six blinks signifies that the feature has been toggled off.

Flush Valve Trouble Shooting Guide

PROBLEM	CAUSE	SOLUTION
User LED continuously blinks every five seconds.	Low battery life.	Replace batteries.
Insufficient flow of water.	Stop Valve improperly adjusted.	Adjust stop valve (open).
Excessive flow of water.	Stop Valve improperly adjusted.	Adjust stop valve (close).
Continuous flow of water.	Debris clogging flush valve's diaphragm.	Replace diaphragm kit (See section entitled "Repair Parts").
User LED does not blink when user is present.	Calibration distance is set too short. Confirm by placing hand 6" in front of the sensor and watching for a blink. If the user blinks, the calibration is set too short.	Reset calibration to desired distance (See section entitled "Adjusting Calibration Distance").
	Batteries are dead. Confirm by placing hand 6" in front of the sensor and watching for a blink. If the user LED does not blink, the batteries are dead.	Replace batteries.
	Battery Tray electrical connection is faulty	Replace battery tray: PERK6000-BD-SM
	LED Sensor Range Set too far. Confirm by placing hand 6" in front of the sensor and waiting at least 30s. If you see only a double blink in this time frame, the sensor may be ranged too far out (constantly detecting a target).	Reset calibration to desired distance (See section titled "Adjusting Calibration Distance")

ZER-SM Series Parts Breakdown

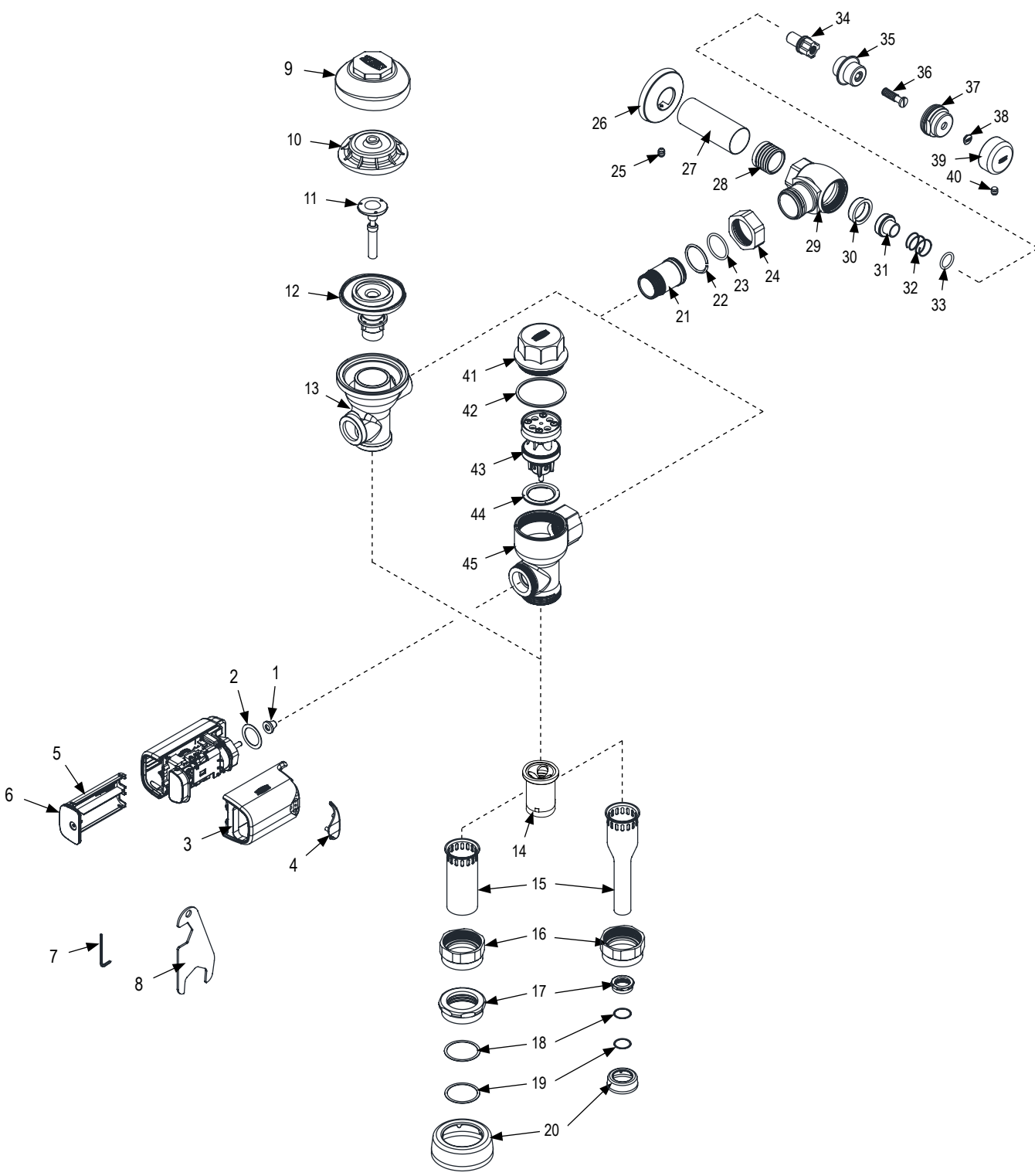

Part Identification

- | | | |
|--|-----------------------------------|---|
| 1. Valve Cup Seal | 16. Vacuum Breaker Tube Nut | 31. Piston |
| 2. Valve Gasket | 17. Spud Nut | 32. Stop Spring |
| 3. Metal Cover, Lens, Electronics Assembly | 18. Spud Friction Washer | 33. Guide O-Ring |
| 4. Sensor Lens | 19. Spud Sleeve | 34. Piston Guide |
| 5. Battery Drawer Assembly | 20. Spud Escutcheon | 35. Guide Holder |
| 6. Battery Drawer O-Ring | 21. Tailpiece | 36. Adjusting Screw |
| 7. Hex Key | 22. Snap Ring | 37. Stop Cap |
| 8. Valve Nut Wrench | 23. Tailpiece O-Ring | 38. Snap Cap Screw Cover |
| 9. Diaphragm Valve Body Cover | 24. Locking Nut | 39. Vandal - Resistant Control Stop Cover |
| 10. Plastic Cover | 25. Setscrew for Cast Wall Flange | 40. Setscrew for Control Stop Cover |
| 11. Trip Mechanism | 26. Cast Wall Escutcheon | 41. Metro Valve Body Cover |
| 12. Diaphragm Repair Kit | 27. Supply Cover Tube | 42. Metro Valve Body Vover Gasket |
| 13. Diaphragm Valve Body | 28. Sweat Solder Adapter | 43. Internal Kit |
| 14. Vacuum Breaker Duckbill | 29. Stop Body | 44. Main Seat |
| 15. Vacuum Breaker Tube | 30. Piston Seal | 45. Metro Valve Body |

Diaphragm Valve Covers and Repair Kits	Product No.
Outside Cover - CP - Item 10	P6000-LL-CP
Inside Cover - Item 11	P6000-L
Low Consumption Closet Kit - 1.28 gal. flush	P6000-ECA-HET
Low Consumption Closet Kit - 1.6 gal. flush	P6000-ECA-WS1
Water Saving Closet Kit - 3.5 gal. flush	P6000-ECA-WS
Full Flow Closet Kit - 4.5 gal. flush	P6000-ECA-FF
Ultra Low Flush Urinal Kit - 0.125 gal. flush	P6000-EUA-ULF
Extra Water Saver Urinal Kit - 0.5 gal. flush	P6000-EUA-EWS
Low Consumption Urinal Kit - 1.0 gal. flush	P6000-EUA-WS1
Water Saving Urinal Kit - 1.5 gal flush	P6000-EUA-WS
Full Flush Urinal Kit - 3.0 gal. flush	P6000-EUA-FF

Metro Valve Covers and Repair Kits	Product No.
Outside Cover - CP - Item 41	P6200-LL-CP
0.125 gpf Outside Cover - Item 41	P6200-LL-ULF-CP
Outside Cover O-Ring - Item 42	P6000-ECA-HET
3.5 gpf Integral Repair Kit, Item 43	P6200-EC-WS
1.5 gpf Integral Repair Kit, Item 43	P6200-EU-WS
1.6 gpf Low Consumption Closet Kit, Item 43	P6200-EC-WS1
1.0 gpf Low Consumption Urinal Kit, Item 43	P6200-EU-WS1
1.28 gpf High Efficiency Closet Kit, Item 43	P6200-EC-HET
0.5 gpf High Efficiency Urinal Kit, Item 43	P6203-EU-EWS
0.125 gpf Ultra Low Flush Kit, Item 43	P6203-EU-ULF
Main Seat, Item 44	P6000-S-30
0.125 gpf Main Seat, Item 44	P6200-MS-ULF

Repair Parts - Inside Parts	Product No.
Urinal Relief Valve - Item 12	P6000-EU13
Closet Relief Valve - Item 12	P6000-EC13

Flush Connections and Spud Coupling Kits	Product No.
Flush Tube Assembly for Flush Valves Includes Items 15-19, Specify Diameter and Length	P6000-A
Vacuum Breaker Repair Kit, Item 17	P6000-B
Spud Coupling Assembly Includes Items 20-23 Specify Size.	P6000-H

Control Stop Repair Kit and Parts	Product No.
Control Stop Repair Kit for 1" and 3/4", Includes Items 33-39	P6000-D-SD
Seal Seat for 1" and 3/4", Includes Item 33	P6000-D42
VP Control Stop Repair Kit for 1" and 3/4", Includes Items 33-39	P6000-D-VP
Sweat Solder Connection with Cast Wall Flange, Includes Items 29-31	P6000-YBYC

Adjustable Tailpieces	Product No.
Adjustable Tailpiece for Standard Flush Valve Includes Items 24-26	P6000-J1
Tailpiece Coupling Assembly Includes Items 25-27	P6000-K
Tailpiece Locking Ring Includes Item 25	P6000-C30
Tailpiece O-Ring Includes Items 26	P6000-C31
Coupling Nut Includes Item 27	P6000-C32

Battery Tray	Product No.
Battery Tray for ZER-SM - Items 5-6	PERK6000-BD-SM

